

PLAN
(FAR SIDE)

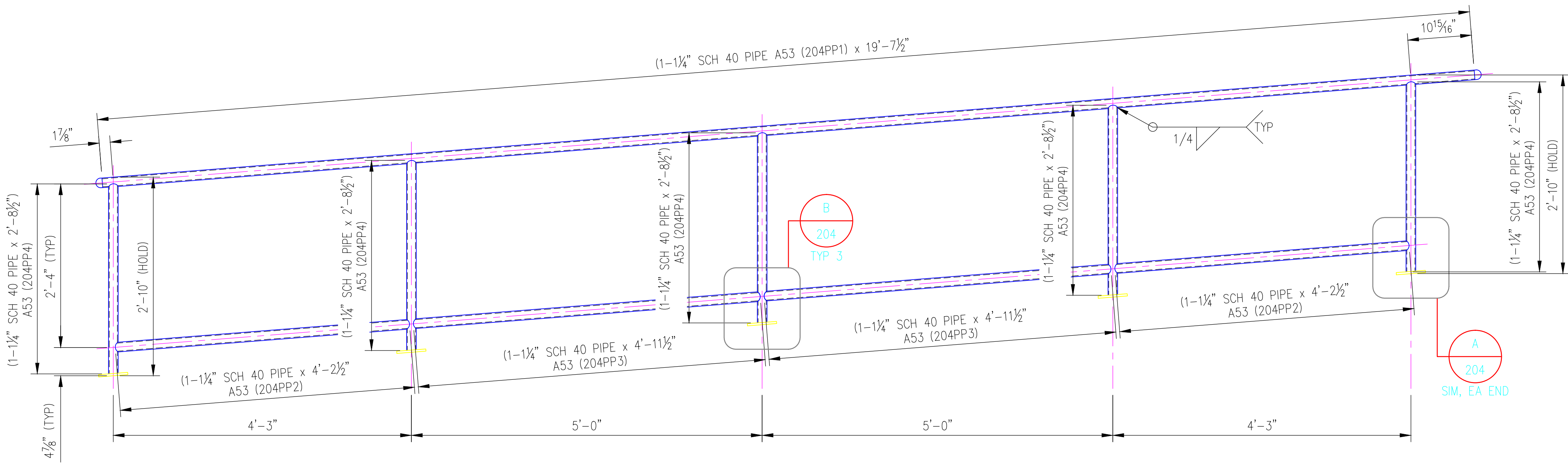

ELEVATION
(FAR SIDE)

RAMP HANDRAIL
SCALE: 1"=1'-0"
204A
ONE REQ'D

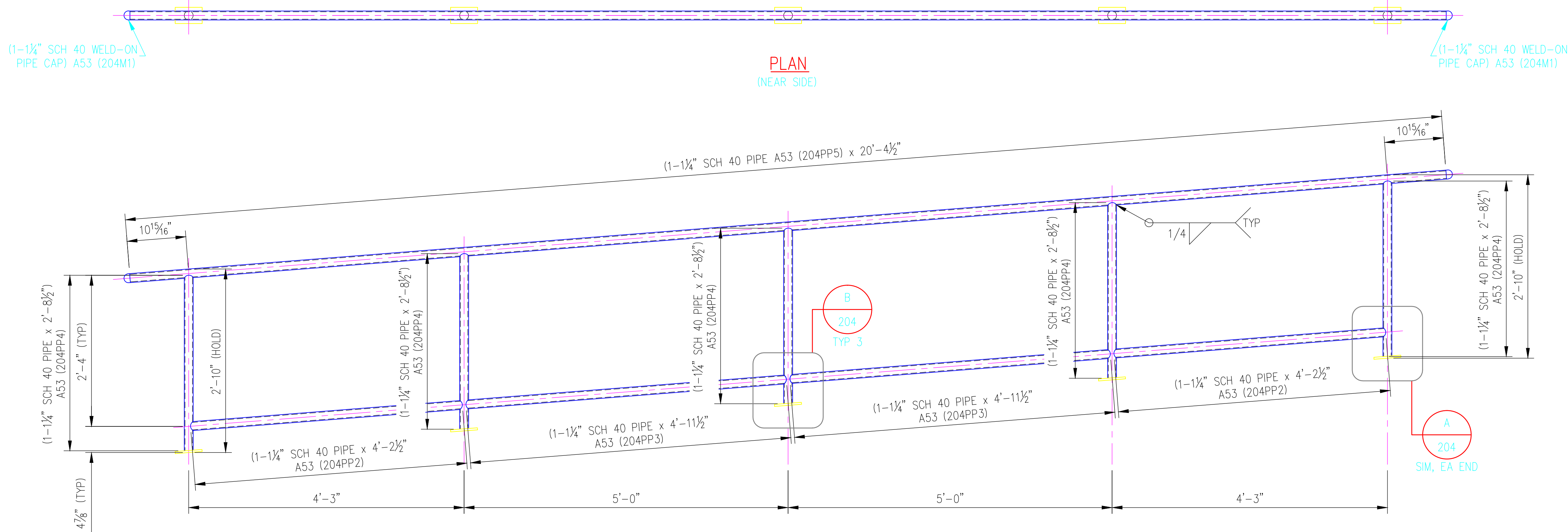

PLAN
(NEAR SIDE)

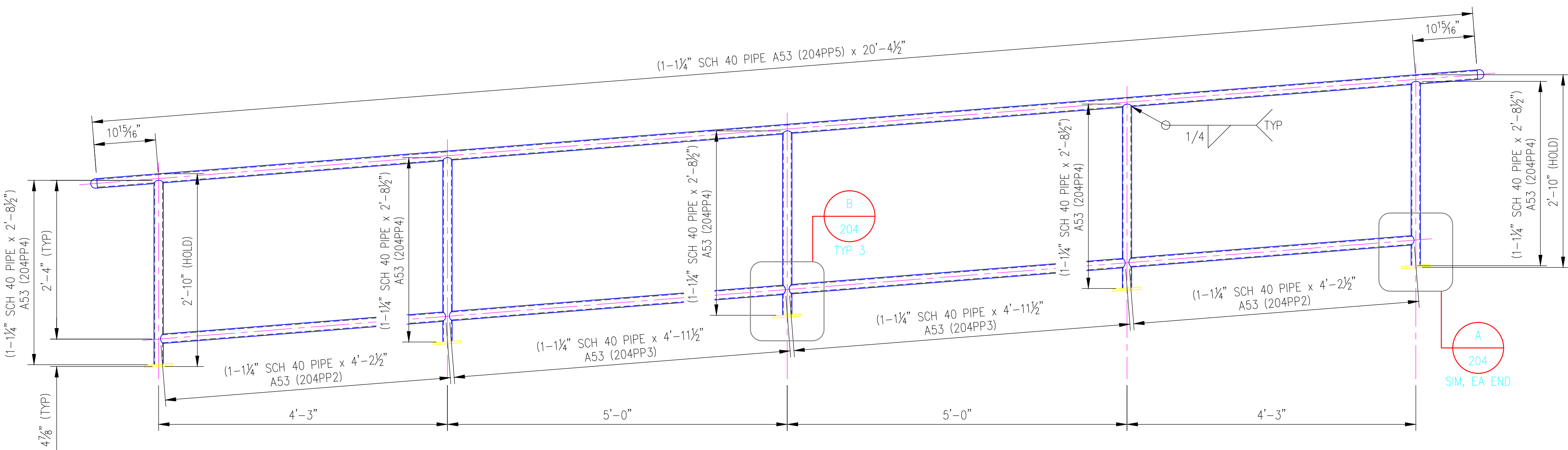

ELEVATION
(NEAR SIDE)

RAMP HANDRAIL
SCALE: 1"=1'-0"
204B
ONE REQ'D

BILL OF MATERIAL

ITEM NO.	SHIP MARK	PIECE MARK	NO. OF PIECES	DESCRIPTION	LENGTH		REMARKS
					FEET	INCHES	
204A			1	RAMP HANDRAIL-FAR SIDE			
204PP1			1	1 1/4" SCH 40 PIPE	19	7 1/2	A53
204PP2			2	1 1/4" SCH 40 PIPE	4	2 1/2	A53
204PP3			2	1 1/4" SCH 40 PIPE	4	11 1/2	A53
204PP4			5	1 1/4" SCH 40 PIPE	2	8 1/2	A53
204BP1			5	R 3/8"x3	0	5	A36
204M1			2	1 1/4" SCH 40 PIPE CAP	-	-	A53, WELD-ON
204B			1	RAMP HANDRAIL-NEAR SIDE			
204PP5			1	1 1/4" SCH 40 PIPE	20	4 1/2	A53
204PP2			2	1 1/4" SCH 40 PIPE	4	2 1/2	A53
204PP3			2	1 1/4" SCH 40 PIPE	4	11 1/2	A53
204PP4			5	1 1/4" SCH 40 PIPE	2	8 1/2	A53
204BP1			5	R 3/8"x3	0	5	A36
204M1			2	1 1/4" SCH 40 PIPE CAP	-	-	A53, WELD-ON
				FIELD BOLTS			
20				3/8" EXPANSION ANCHOR	0	3 3/4	TYPE 304 SSSL

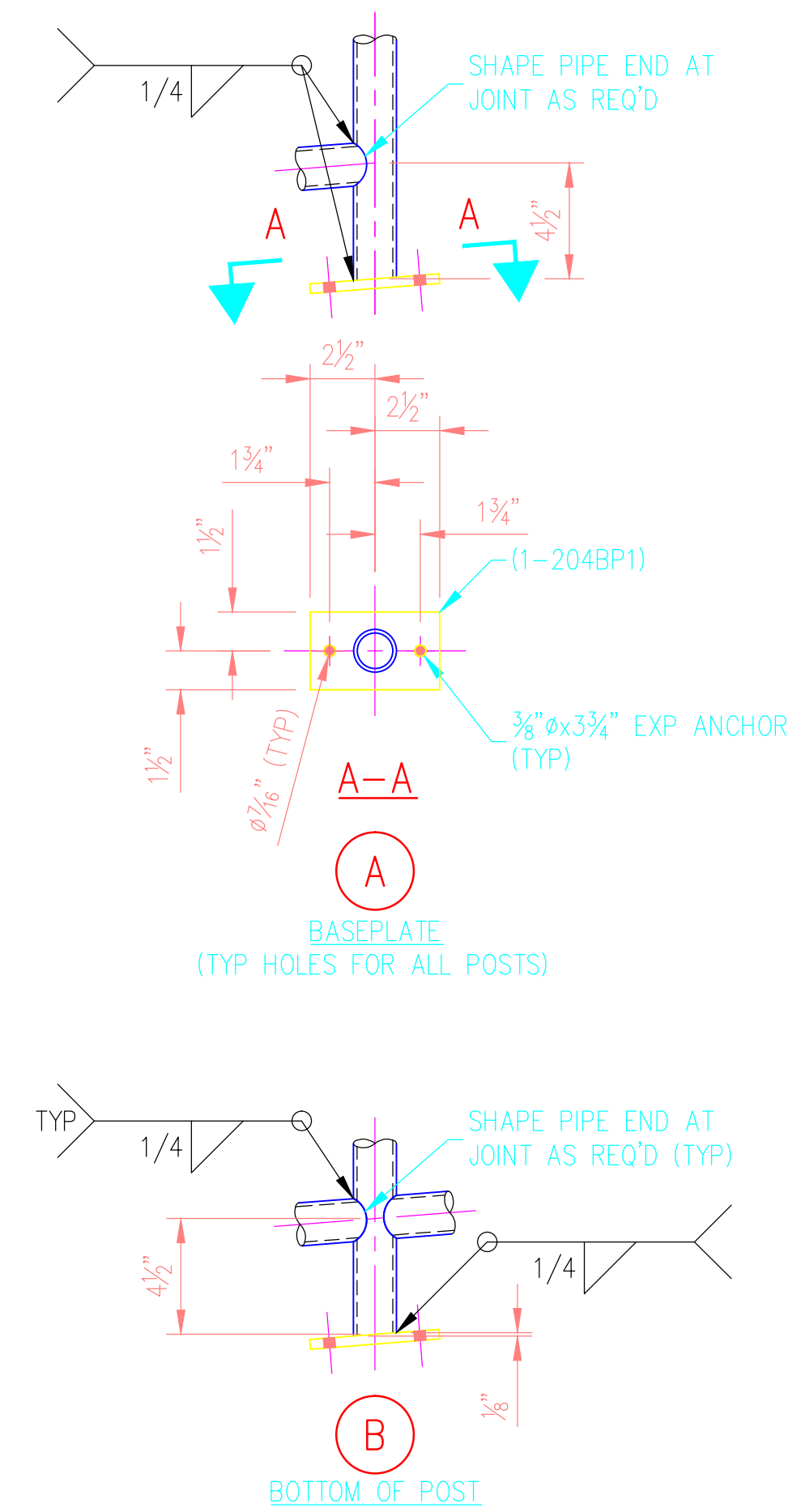

MATERIAL, COATING & FABRICATION SPECIFICATIONS

MATERIALS & FABRICATION	COATINGS
ALL TUBE SECTIONS: A500 GRADE B	FINISH-ONE SHOP COAT PRIMER
ALL PIPES: A53, GR. B, SCH. 40	
WIDE FLANGES, PLATES & BARS: A36	
ALL OTHER STEEL: A36	
WELDED, HEADED ANCHOR STUDS: A108	
HEADED ANCHOR BOLTS: A307	
INDOOR ANCHOR BOLTS: A307	
OUTDOOR ANCHOR BOLTS: TYPE 304 SSSL	
ALL WELDING: AWS D1.1	
SURFACE PREP: SSPC-SP6	
SCALE: AS NOTED	

DATE:	
REV:	
REVISION DESCRIPTION:	
ENGINEER'S STAMP:	

ANDY'S BEST CAD
1323 CARLYLE PARK CIRCLE
HIGHLANDS RANCH, CO 80129
303-808-3352
WWW.ANDYSBESTCAD.COM

DRAWN: A. LANDT
DESIGNED: A. LANDT
CLIENT: 02/15/16
DATE: AS NOTED
SCALE: AS NOTED

PROJECT:

RAMP HANDRAIL
DETAILS

DRAWING TITLE:

DRAWING NO.:
S07/204
OF

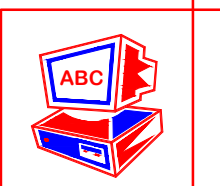

©2016 ANDY'S BEST CAD. ALL RIGHTS RESERVED. THIS DRAWING IS THE PROPERTY OF ANDY'S BEST CAD AND IS PROTECTED BY COPYRIGHT LAWS OF THE UNITED STATES OF AMERICA. ANY UNAUTHORIZED USE OF THE INFORMATION CONTAINED HEREIN OR PART THEREOF IS STRICTLY PROHIBITED. RECEIPT OF POSSESSION THEREOF DOES NOT CONVEY OR TRANSFER ANY RIGHT TO MAKE, COPY, MANUFACTURE AND/OR SELL EITHER THE DRAWING OR THE ITEMS SHOWN THEREIN.