

PLAN VIEW B-B

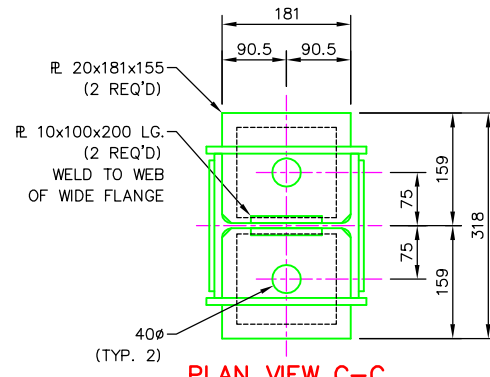

PLAN VIEW C-C

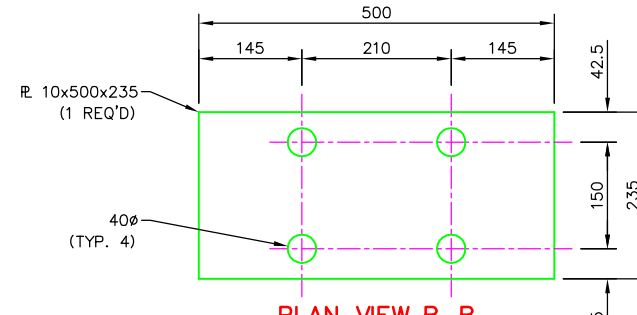

PLAN VIEW B-B

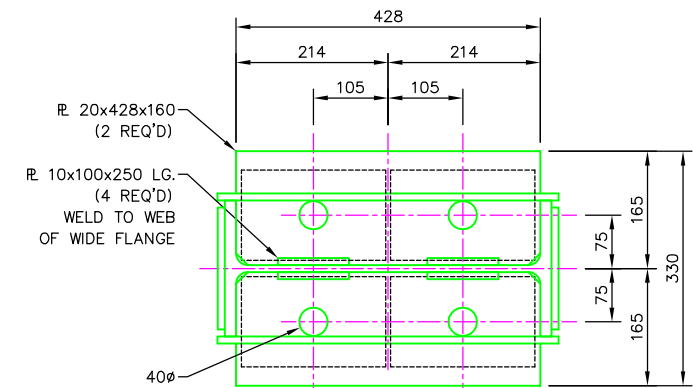

PLAN VIEW C-C

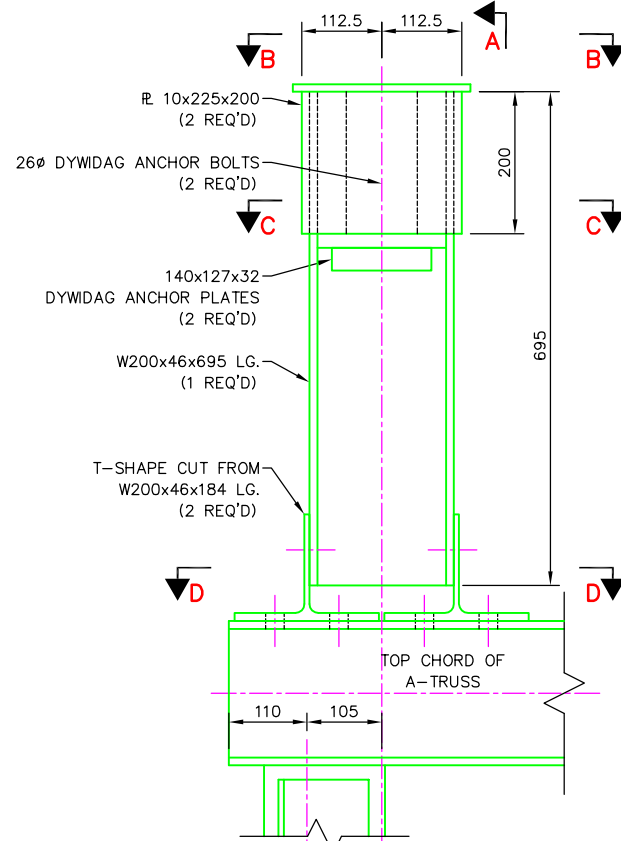

ELEVATION

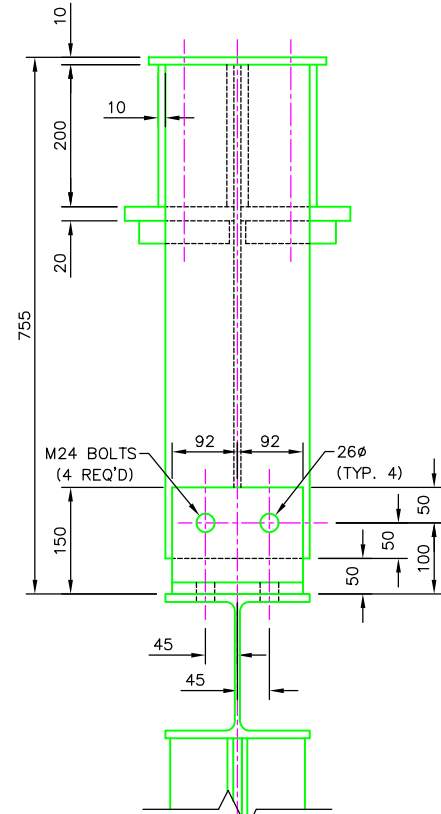

SECTION A-A

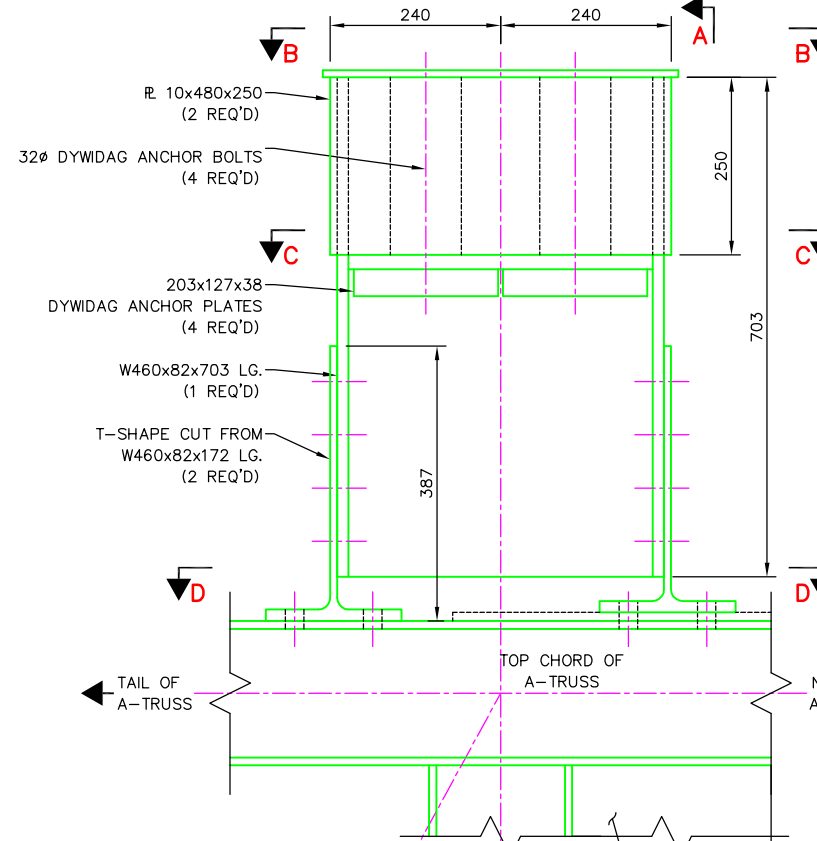

ELEVATION

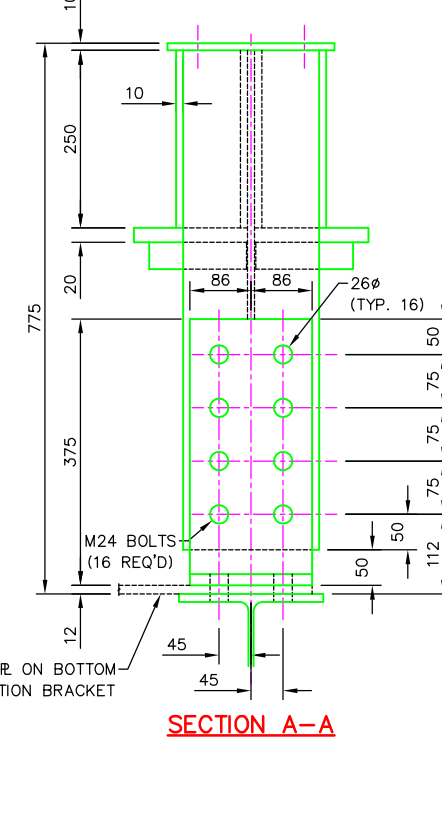

SECTION A-A

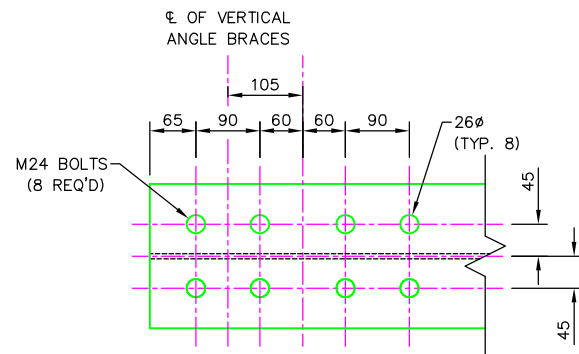

PLAN VIEW D-D
BOLT LAYOUT ON TOP CHORD

A-TRUSS REAR ANCHOR
(2 REQ'D)

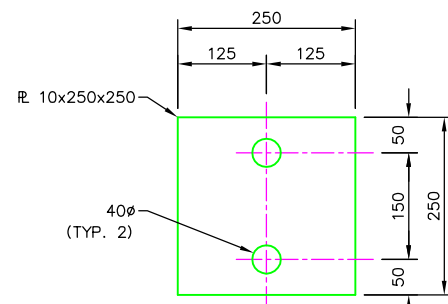
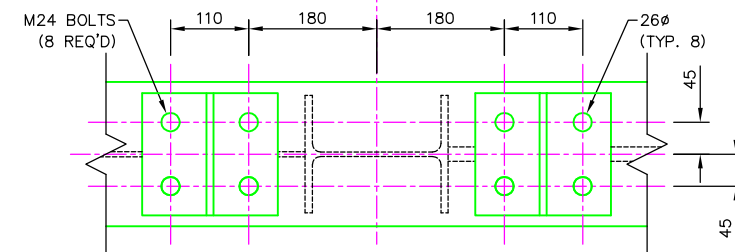

PLATE SPACER
(4 REQ'D)



PLAN VIEW D-D
BOLT LAYOUT ON TOP CHORD

A-TRUSS CENTER ANCHOR-DETAIL 23
(2 REQ'D)

NOTES:
1. ALL CONNECTIONS ARE TO USE 6mm
FILLET WELDS ALL-AROUND UNLESS
NOTED OTHERWISE

DO NOT SCALE DRAWINGS
ALL DIMENSIONS IN MILLIMETERS
UNLESS NOTED OTHERWISE

DATE:	
REV:	
REVISION DESCRIPTION:	
	
ANDY'S BEST CAD 9715 S. MERIBULA ST. LITTLETON, CO 80130 303-791-1622 WWW.ANDYSBESTCAD.COM	
DRAWN: A.LANDT	DESIGNED: 08/03/04
CLIENT: LITTLETON, CO 80130	SCALE: 1:10
DRAWING TITLE: CENTER AND REAR ANCHORS	
DRAWING NO.:	S02/221
	OF