

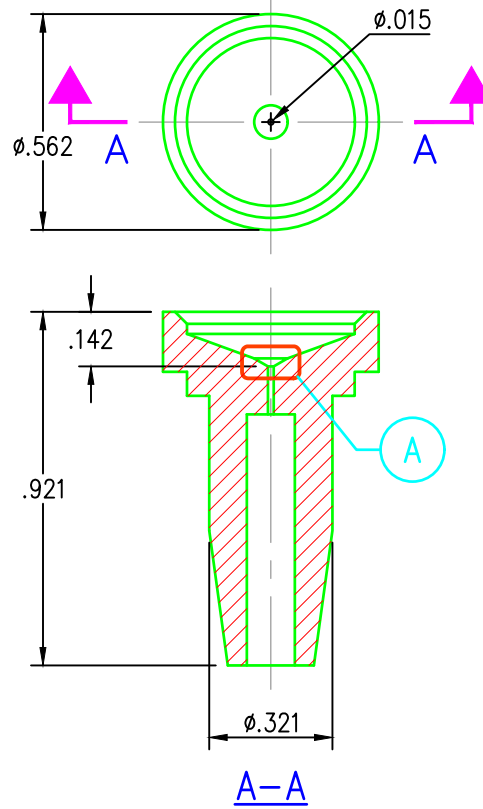

REVISION HISTORY

REV	DESCRIPTION	DATE	APPROVED
-----	-------------	------	----------



A
GRIND DETAIL
BALL SEAT

- NOTES:
 1. DIMENSIONS AND TOLERANCES PER ASME Y14.5-2009.
 2. REMOVE ALL BURRS AND SHARP EDGES.

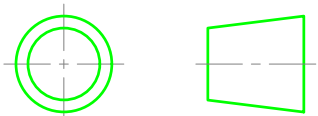
	UNLESS OTHERWISE SPECIFIED DIMENSIONS ARE IN INCHES (IN)	APPROVALS	DATE	COMPANY NAME					
	TOLERANCES: .X ± .031 .XX ± .010 .XXX ± .005 .XXXX ± .0050 ANGULAR ± 1°	DRAWN ABC	09/29/17				DRAWING TITLE VALVE SEAT		
	THIRD ANGLE PROJECTION	CHECKED	09/29/17	<table border="1"> <tr> <td>SIZE A</td> <td>DWG NO. M102</td> <td>REV 0</td> </tr> </table>					
	SIZE A	DWG NO. M102	REV 0						
		APPROVED	09/29/17	<table border="1"> <tr> <td>DO NOT SCALE DRAWING</td> <td>SCALE 1:2</td> <td>SHEET 1 OF 1</td> </tr> </table>			DO NOT SCALE DRAWING	SCALE 1:2	SHEET 1 OF 1
DO NOT SCALE DRAWING	SCALE 1:2	SHEET 1 OF 1							
	MATERIAL								
	FINISH								