

ELEVATION
INSIDE FACE
209LHR

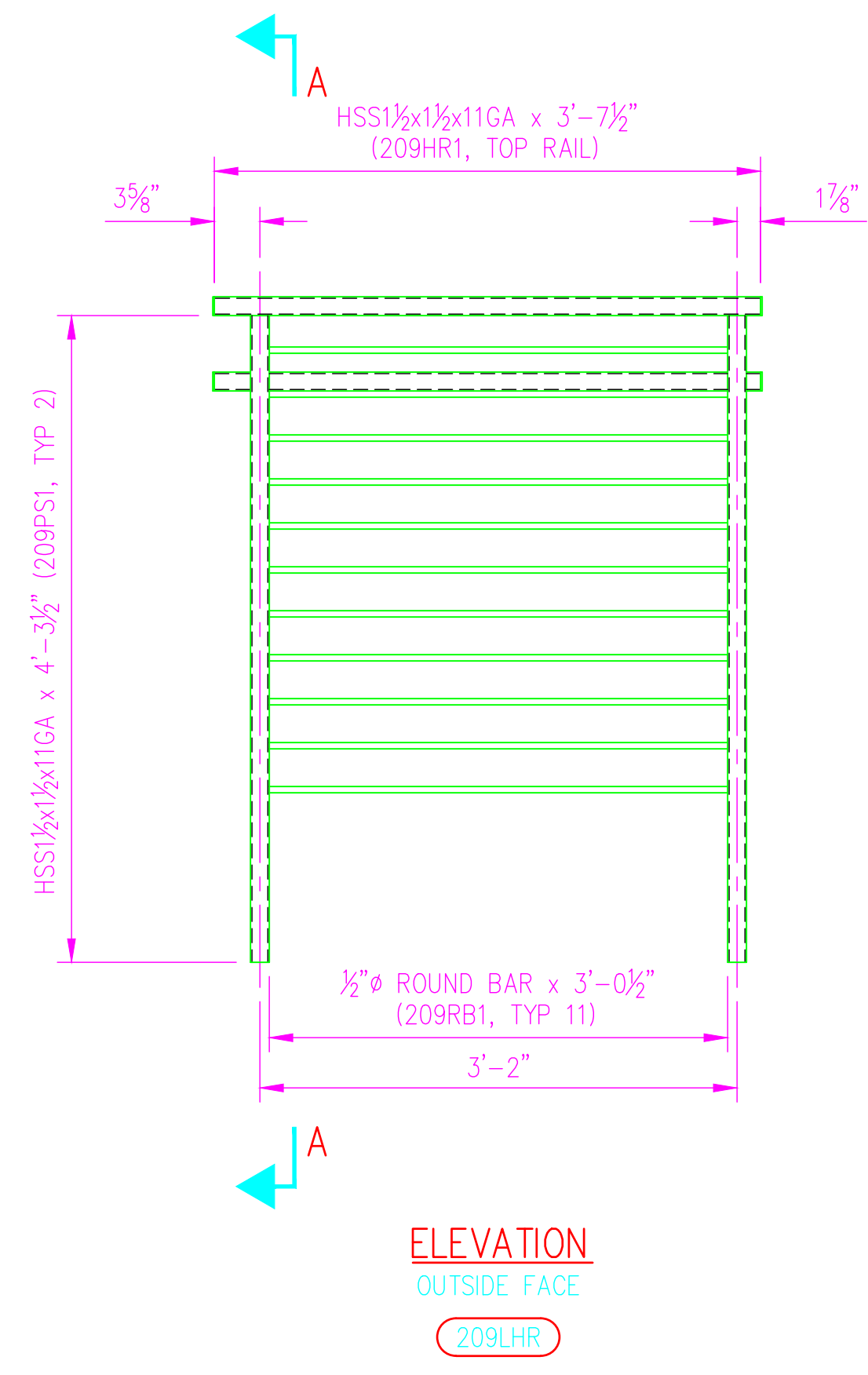

ELEVATION
OUTSIDE FACE
209LHR

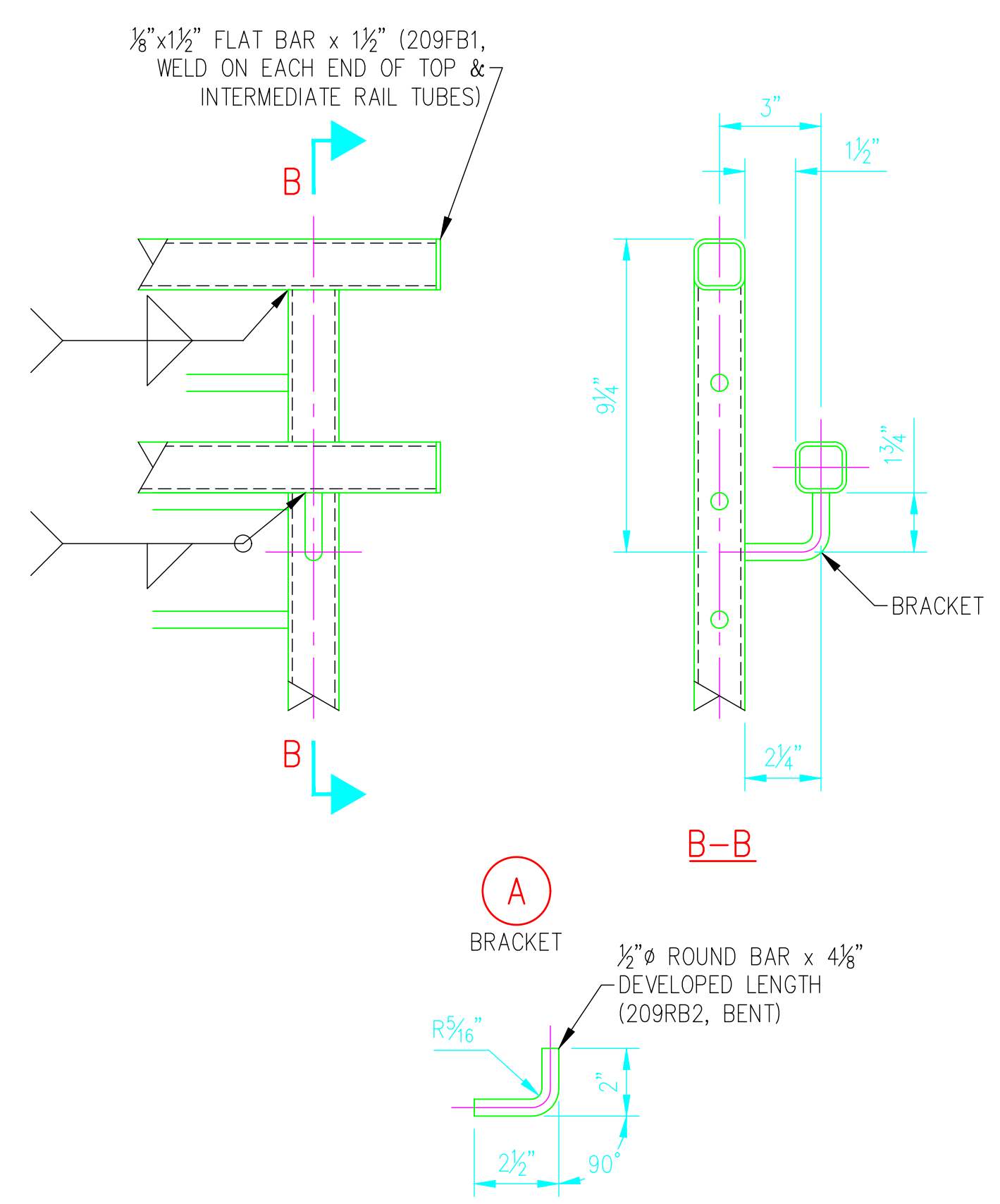
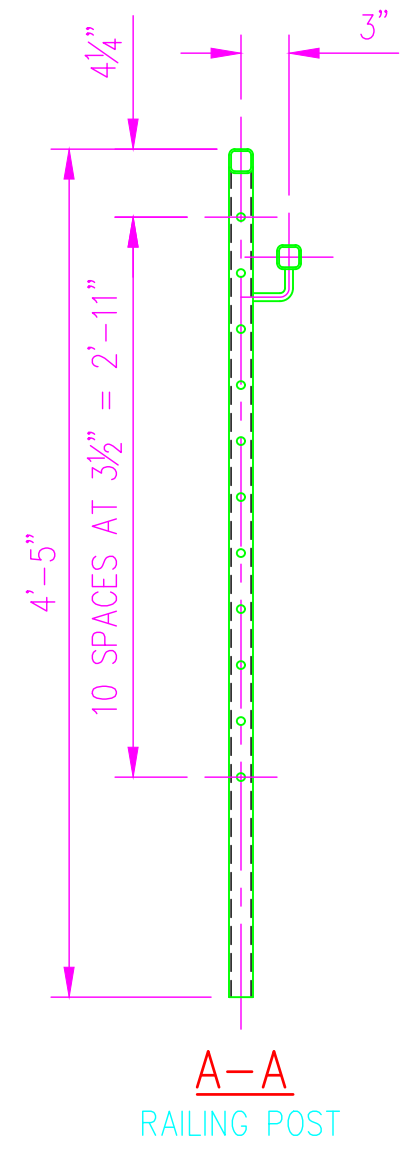

A-A
RAILING POST

BILL OF MATERIAL					
MARK	QTY	DESCRIPTION	FT	IN	REMARKS
209LHR	1	LANDING HANDRAIL			
209HR1	2	HSS1 1/2 x 1 1/2 x 11 GA	3	7 1/2	
209PS1	2	HSS1 1/2 x 1 1/2 x 11 GA	4	3 1/2	
209RB1	11	1/2\"/>			

ALL SIZES SHOWN ARE FOR FINISHED MATERIALS

FABRICATION NOTES

- FIELD VERIFY ALL DIMENSIONS & ATTACHMENTS PRIOR TO FABRICATION & ERECTION OF HANDRAILS.
- ALL FIELD WELDED CONNECTIONS SHALL BE CONTINUOUS AND GROUND SMOOTH FOR FLUSH TRANSITIONS. ANY GALVANIZED COATINGS DAMAGED DURING FIELD WELDING AND ERECTION SHALL BE REPAIRED WITH GALVANIZED REPAIR PAINT. PROTECT EXISTING FINISHES DURING CONSTRUCTION.
- REMOVE BURRS AND EASE EDGES TO AN APPROXIMATE RADIUS OF 1/32\"/>

MATERIAL, COATING & FABRICATION SPECIFICATIONS

MATERIALS & FABRICATION	COATINGS
HSS TUBES: ASTM A500 OR A513	HANDRAIL SECTIONS SHALL BE HOT-DIPPED GALVANIZED AFTER FABRICATION PER ASTM A123.
ROLLED CHANNELS, ANGLES, PLATES, ROUND BARS, FLAT BARS: ASTM A36	REPAIR DAMAGED GALVANIZED COATINGS WITH GALVANIZED REPAIR PAINT.
PIPES:	
ROLLED W SHAPES:	GALVANIZED REPAIR PAINT SHALL BE WELD-AID B-100 BRITZ ZINC.
HEADED ANCHOR STUDS:	
FASTENERS:	
SURFACE PREP: SSPC-SP6	
WELDING: AWS D1.1, AWS A5.1 CLASS E70XX-LOW HYDROGEN ELECTRODES	DO NOT SCALE DRAWINGS. ALL DIMENSIONS IN FT & IN UNLESS NOTED OTHERWISE.

DATE: _____

REVISION DESCRIPTION: _____

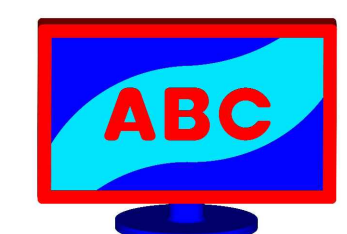

ANDY'S BEST CAD
1323 CARLYLE PARK CIRCLE
HIGHLANDS RANCH, CO 80129
303-808-3352
WWW.ANDYSBESTCAD.COM

DRAWN: ABC
DESIGNED: ABC
CLIENT: ABC
DATE: 12/06/21
SCALE: 1" = 1'-0"

PROJECT: REHABILITATION FACILITY
AURORA, COLORADO
HANDRAIL SHOP DRAWINGS

DRAWING TITLE: LANDING HANDRAIL

DRAWING NO.: S209
OF _____

©2021 ANDY'S BEST CAD. ALL RIGHTS RESERVED. THIS DRAWING IS THE PROPERTY OF ANDY'S BEST CAD AND IS PROTECTED BY COPYRIGHT LAWS OF THE UNITED STATES OF AMERICA. ANY UNAUTHORIZED USE OF THE INFORMATION CONTAINED HEREIN OR PART THEREOF IS STRICTLY PROHIBITED. RECEIPT OR POSSESSION THEREOF DOES NOT CONVEY OR TRANSFER ANY RIGHT TO MAKE, COPY, MANUFACTURE AND/OR SELL EITHER THE DRAWING OR THE ITEMS SHOWN THEREON.