

REVISION HISTORY

REV	DESCRIPTION	DATE	APPROVED
-----	-------------	------	----------

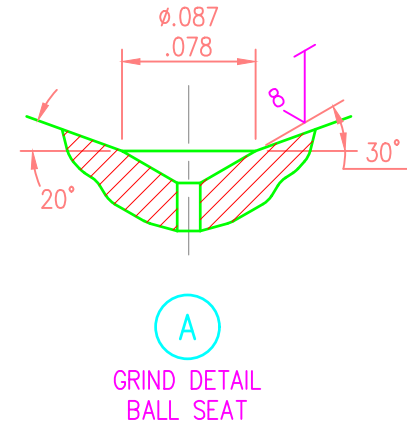
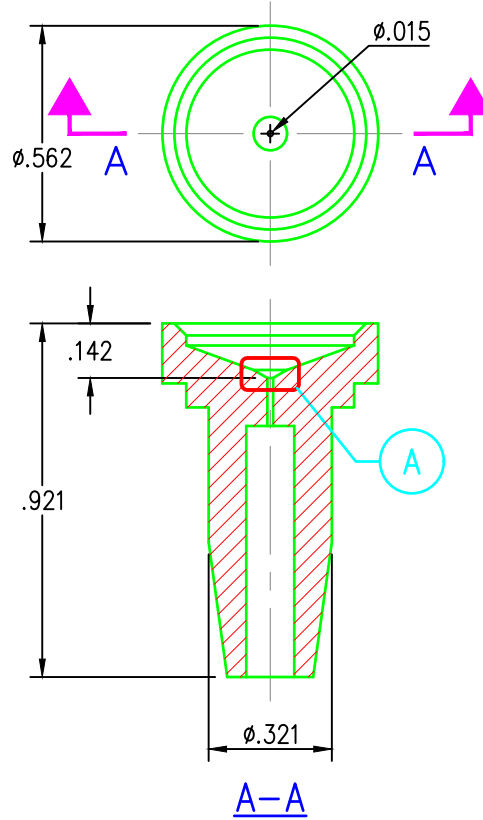

GRIND DETAIL
BALL SEAT

NOTES:

1. DIMENSIONS AND TOLERANCES PER ASME Y14.5-2009.
2. REMOVE ALL BURRS AND SHARP EDGES.

A-A

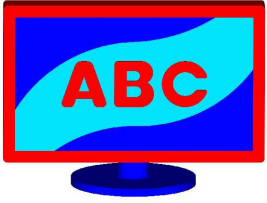
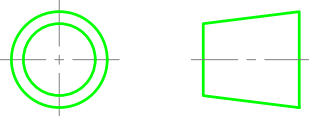
	UNLESS OTHERWISE SPECIFIED DIMENSIONS ARE IN INCHES (IN)	APPROVALS	DATE	COMPANY NAME	
	TOLERANCES:	DRAWN	09/29/17		
	.X ± .031 .XX ± .010 .XXX ± .005 .XXXX ± .0050 ANGULAR ± 1°	CHECKED	09/29/17	VALVE SEAT	
	THIRD ANGLE PROJECTION	APPROVED	09/29/17		
	MATERIAL	DO NOT SCALE DRAWING		SHEET 1 OF 1	
		FINISH	SCALE 1:2		